

BALL VALVES INTEC

K214, DN80 - DN250, PN16/40
trunnion mounted ball, PEEK seated,
both sides spring loaded seat rings

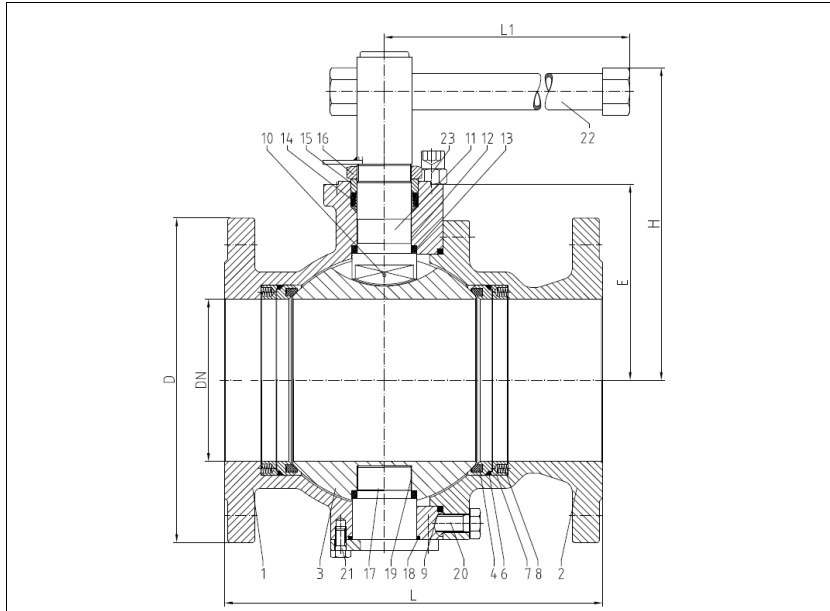

Flanged ball valve
full bore
face to face acc. to EN 558, GR.1
face to face acc. to EN 558, GR.27
flanges acc. to EN 1092

Specification:

Two-piece ball valve with flanges acc. to EN 1092, face to face dimensions acc. to EN 558, GR.1/GR.27, full bore, blow-out-proof stem, body material stainless steel (1.4408) or carbon steel (1.0619), antistatic device, free of non ferrous metals, trunnion mounted ball, seats full chambered, stem packing Graphite/KFGN/KFAM cone ring system dynamic loaded adjustable, top flange DIN EN ISO 5211, approved by PED, certified acc. to GERMAN clean air act VDI 2440, with lever.

Also possible as high-temperature version up to +260°C.

Marking: INTEC K214

No.	Part	Material	Material
Standard design			
1	body	1.0619	1.4408
2	cap	1.0619	1.4408
3	ball	1.4408	
4	seat (flanged)	PEEK/Graphite/1.4571-1.4404 PEEK mod./Graphite/1.4571-1.4404	
6	seat seal	KF	
7	follower ring	1.4571/1.4404	
8	spiral spring	1.4401	
9	body seal	KF	
10	antistatic element	1.4401/1.4571/1.4404	
11	stem	1.4462	
12	below stem bearing	1.4401/KF	
13	below seal	KFGN/Graphite	
14	upper seal	KFAM/Graphite	
15	upper stem bearing	PEEK	
16	hex. nut self-locking	A2/1.4301	
17	trunnion	1.4571/1.4404	
18	trunnion seal	KF	
19	bearing	1.4401/KF	
20+21	hex. screw	A4-70	
22	lever	1.4408/1.4308/steel zincplated	
23	stopper	A2	
Fire-Safe design			
5	combined body seal	KF-Graphite	
6	seat seal	Graphite	
8	spiral spring	Inconel X750	
11	Fire-Safe seal	Graphite	
	ring	1.4571/1.4404	
	thrust washer	PEEK	
18	trunnion seal	KF-Graphite	

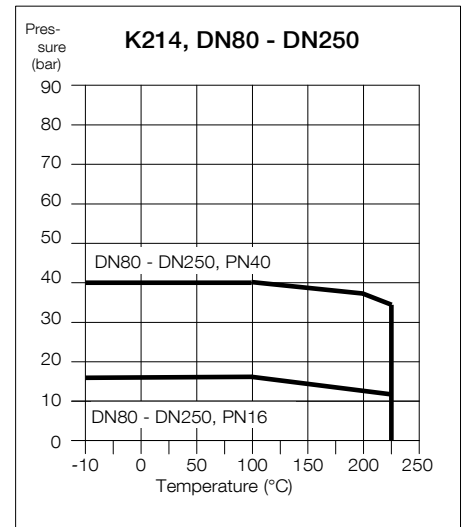

Ordering example:
INTEC K214, DN100, PN40,
GR.27, 1.4408, Fire-Safe

Other flange connections and materials on request.

Dimensions

DN mm	PN	dimensions (mm)				L GR. 1	L GR. 27	D	E	H1	top flange ISO	torque Nm *	ca. weight kg	
		H	L1	GR. 1	GR. 27									
80	40	194	500	310	180	200	112.5	155	F10	294**	26	24		
100	16	221.5	500	350	190	220	137	179.5	F12	238**	34	32		
100	40	221.5	500	350	190	235	137	179.5	F12	456**	35	34		
125	16	246.5	700	-	325	250	164	206.5	F12	255**	-	57		
125	40	246.5	700	-	325	270	164	206.5	F12	521**	-	60		
150	16	263	700	-	350	285	181	229.5	F12	359**	-	80		
150	40	263	700	-	350	300	181	229.5	F12	780**	-	85		
200	16	304	1000	-	400	340	225	284.5	F14	683**	-	140		
200	40	304	1000	-	400	375	225	284.5	F14	1558**	-	150		
250	16	340.5	1200	-	450	405	261.5	321	F14	1092**	-	245		
250	40	340.5	1200	-	450	450	261.5	321	F14	2511**	-	250		

* Necessary torque measured with treated water at Δ P acc. to pressure class and room temperature

** gearbox recommended

Subject to technical modification. 10/2019